

# Product Instruction Manual

**The products category**

★ **Regulating valve**

★ **Switch valve**

★ **Actuator**

# CONTENTS

NAMES OF COMPONENTS . . . . . 1

OVERALL DIMENSION DRAWINGS . . . . . 2  
AND PERFORMANCE PARAMETERS

EXAMPLES OF CONTROL CIRCUITS . . . . . 4

OVERALL PERFORMANCE INDEXES OF . . . . . 8  
ADJUSTING TYPE PRODUCTS

DIMENTION DRAWINGS FOR . . . . . 9  
CONNECTION OF ELECTRIC ACTUATOR

APPLICATION REQUIREMENTS . . . . . 11

INSTALLATION OF ELECTRIC ACTUATOR ONTO VALVE . . . . . 12

ADJUSTMENT OF ELECTRIC ACTUATOR . . . . . 13

ADJUSTMENT OF ADJUSTING TYPE . . . . . 15  
ELECTRIC ACTUATOR

OPERATION AND MAINTENANCE . . . . . 17

6) Error Information and Handle Methods

This controller has the function of self diagnose. The code of error information will be displayed when the abnormal conditions are found by self checking.

SERIES NO.	ERROR CODE	MEANING	HANDLING METHOD
1	PFAL0	No calibration to the positioning	Restart the manual or automatic calibration
2	ERR2	Inner-temperature exceeding alarm	Check temperature settings and reason for over temperature
3	ERR3	Motor for open- operation is plugging	Check the valve, see if it is stuck, and check the actuator, see if the open limit is normal
4	ERR4	Motor for close- operation is plugging	Check the valve, see if it is stuck, and check the actuator, see if the open limit is normal
5	ERR6	The given current is too small	Check the input signal, see if it is normal
6	ERR7	The given current is too large	Check the input signal, see if it is normal
7	ERR8	The valve position is less than down limit	Check the full-close position, see if the adjustment is normal and limit is reliable
8	ERR9	The valve position is more than up limit	Check the full-open position, see if the adjustment is normal and limit is reliable

7) Test Run

Please input the current values in the order of the following table, and check the working conditions of valve and servo controller

Input signal Items for checking	4mA	8 mA	12 mA	16 mA	20 mA
Pointer	SHUT	2.5	5	7.5	OPEN
Valve status(%)	Full close: 0	Opening : 25	Opening: 50	Opening: 75	Opening: 100
Feedback current(mA)	4	8	12	16	20

9、Operation and Maintenance

1) Maintenance and Service

- ① Since the molybdenum-base grease with long service life and good pressure resistance is employed, no lubrication and periodical maintenance are needed.
- ② If the operation of valve is rare, periodically driving the actuator is necessary and checking if there is any abnormal condition.

2) Trouble shooting

Problem	Cause	Remedy
Motor does not start.	The power cord is not plugged in	Plug in the power cord again
	Power line is disconnected or the connection between connector and terminals is loosen	Connect the power line,Connect and fasten the terminal correctly
	Voltage is not right or too low	Check the voltage if it is normal
	The overheat protection device is initiated. (The ambient temperature too high, or valve clogged)	Cool down the temperature of actuator. Check the valve manually, see if it can be opened and closed normally
Indication lamp for ON/OFF does not work	The capacitor for starting is defective	Contact the manufacturer and replace the capacitor
	Bulb damaged	Replace the bulb
	Stroke switch is not proper	Replace the stroke switch
Motor could not stop running when reaching to the limit position	The adjustment of electric limit is not proper	Readjust the cam and make the electric limit work normally
	The action of micro switch is not proper	Replace the micro switch
	The polarity of DC 24V is wrong or phase order of AC 380V main power is wrong connected	Adjust the polarity of DC power or the phase order of 3-phase power
	Wrong connection of stroke switch to control circuit	Adjust the connection

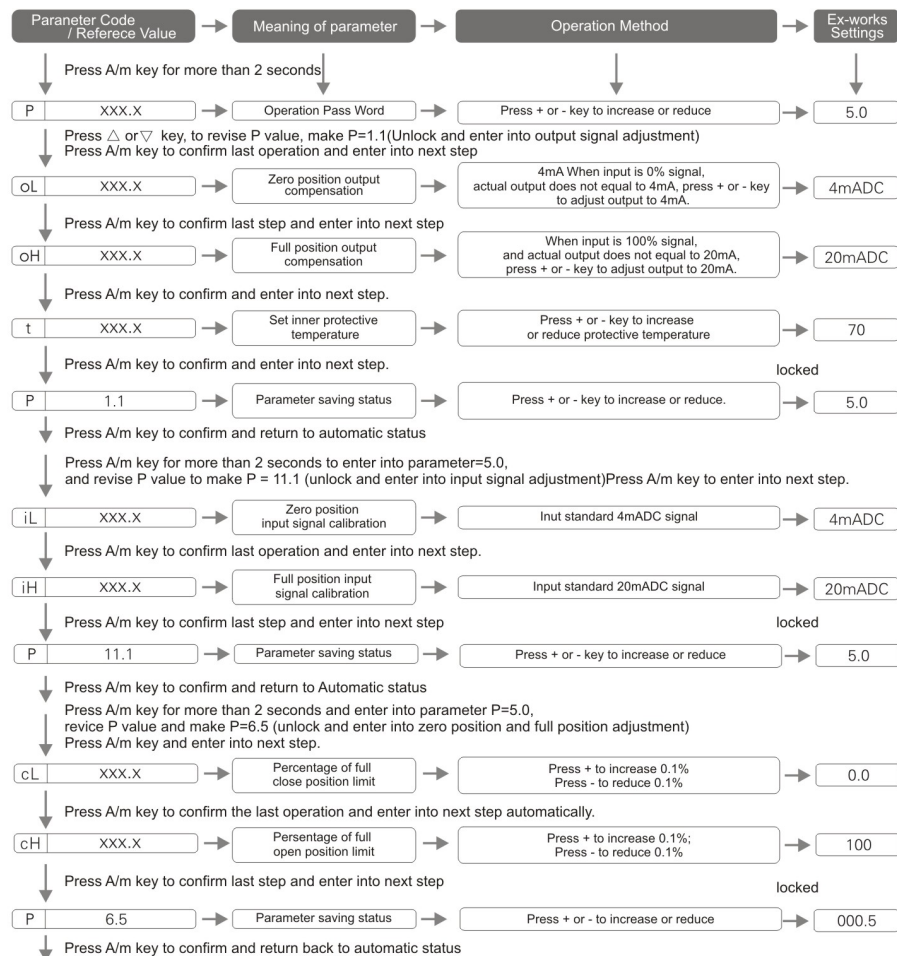

Note:

- 1) During the modification of parameters, the time interval of 8 seconds for the operation of two times pressing keys continuously shall not be exceeded, otherwise the servo-controller will automatically withdraw the parameter setting status, and the present settings will not be saved. You have to restart the setting according to the flow sheet.
- 2) When customer makes the actuator not be able to work normally due to improper parameter setting or error in operation, it is possible to start to recover the settings before ex-works. Press the A/m key for more than 2 seconds, enter into parameter P=5.0, and then press "+" or "-" key, make P=20.1, press A/m key again for confirmation. The actuator will restart the automatic calibration and recover the parameter settings before ex-works and enter into automatic measuring and control status.
- 3) The servo-controller has conversion function of manual (local) and automatic (remote) control. Press "A/m" key, the conversion between manual and automatic can be made. The indication lamp for manual / automatic status lights with red, it means it is manual control mode (green is for automatic status and yellow is for calibration status), at this time it is possible to have the operation of open and close of the valve by pressing "+" "-" keys.

\* The above-mentioned parameter ex-works values are precisely set. Please not change them if no particular needs.

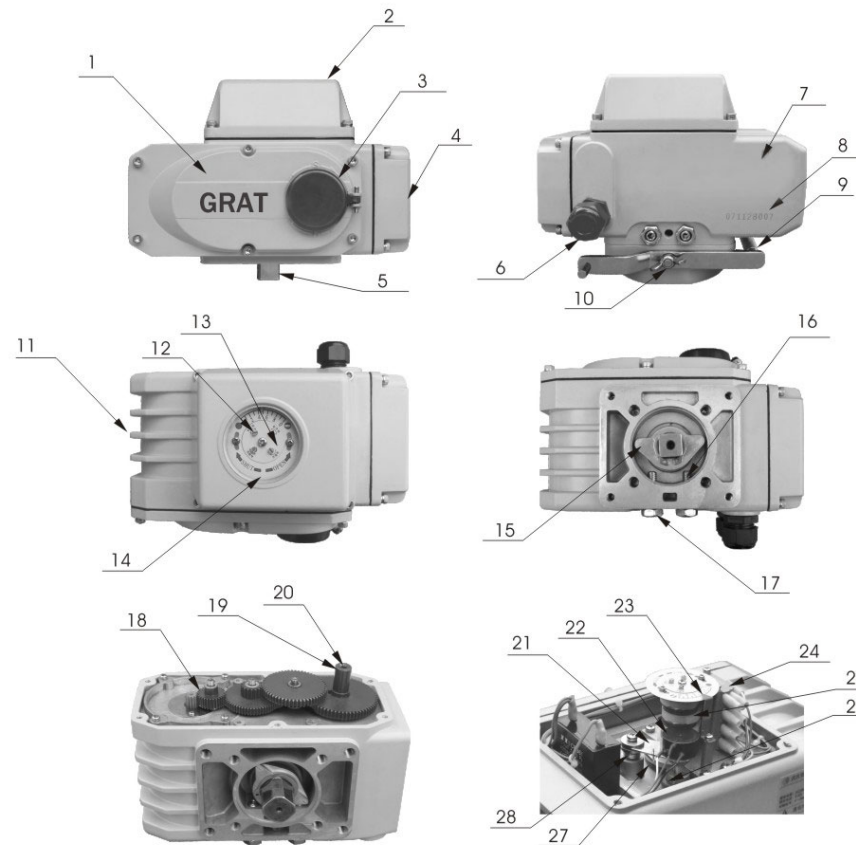

- |  |                                     |
|--|-------------------------------------|
| 1 Cover of Driving Side                  | 15 Dog for Mechanical Limit         |
| 2 Cover for Electric Elements            | 16 Adjusting Screw                  |
| 3 Rubber Cover for Manual Operation Port | 17 Lock Nut                         |
| 4 Cover for Junction Box                 | 18 Reducing Gear Group              |
| 5 Output Shaft                           | 19 Worm Shaft                       |
| 6 Water-proof Cable Connector            | 20 Manual Operation Port            |
| 7 Name Plate                             | 21 Mounting Plate for Potentiometer |
| 8 Code No. of Ex-works Product           | 22 Potentiometer                    |
| 9 Operation Crank                        | 23 Pointer                          |
| 10 Butterfly Type Screw                  | 24 Micro Switch                     |
| 11 Casing                                | 25 Tooth ring                       |
| 12 Adjusting Shaft                       | 26 Gear for Potentiometer           |
| 13 Indication Board                      | 27 Gear for Opening                 |
| 14 Scale Plate                           | 28 Tension Spring                   |

OVERALL DIMENSION DRAWINGS FOR  
EA-02

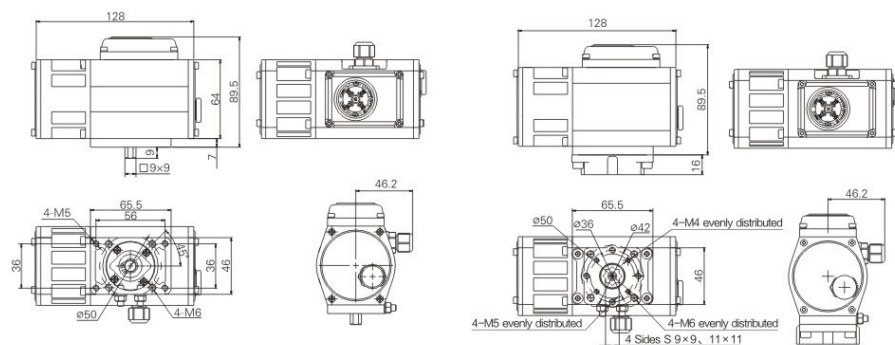

Standard Type

Direct Installation Type

Type Parameters	EA-02			
	DC24V	AC24V	AC110V	AC220V
Performance				
90°Standard, Time/Torque	20S/20Nm			
90°Selectable, Time/Torque				
Turning Angle (°)	0~360			
Motor Power (W)	8	6	6	6
Rated Current (A)	0.7	1.3	0.32	0.16
Total Weight (Kg)	1.2			
Insulation Resistance (MΩ)	100/250VDC		100/500VDC	
Voltage-withstand Class	AC500V/ one minute		AC1500V/ one minute	
Protection Class of casing	IP 67			
Installation Angle	360° at any angle			
Electric Interface	7-Core Multiple Cable			
Ambient Temperature (°C)	-30~+60			
Optional Control Circuit	Type A: Ordinal switch type; Type C : Resistance signal feedback		Type B: Passive signal feedback type; Type G: DC current control type;	
Optional Function	★Stainless steel support, coupling ★Direct installation board, coupling (ISO5211 Standard) ★Over torque protector ★Heater for eliminating moisture			

8、Adjustment of Adjusting Type (E Type Electric Actuator)

- 1) Please refer to the requirements of overall adjustment of electric actuator in the previous section of this operation manual and correctly adjust ZERO position (4mA position, corresponding to full-close position of valve), FULL position (20mA position, corresponding to full-open position of valve), mechanical limits of electric actuator and meet the requirements of Fig. 11.
- 2) Correctly connect the input and output signal as well as the power connection according to the indication on the panel of servo controller (Fig. 12), confirmation is necessary at the same time.
- 3) Turn on the power, the indication lamp and digital tube will blink twice, which shows the starting is normal.
- 4) Positioning accuracy settings: It is possible to have settings by means of accuracy selection switch on the panel. It is divided into 0 to 9 (total ten positions). The positioning accuracy is adjusted from 0.4% to 2.2%. When the setting of the switch increases, the accuracy orderly reduces. Generally the factory sets the switch to "1", which corresponds to the positioning accuracy of 1%.
- 5) Settings of control signal interruption mode:  
The presetting is realized by means of control signal interruption mode switch. When the switch is located to "stop" position, the actuator will stop at the present position at the time of interruption signal; when the switch is located to "open" position, the green indication lamp will light and the actuator will drive the valve to full- open position; when the switch is located to "close" position, the actuator will drive the valve to full-close at the time of interruption signal.
- 6) Settings of function mode:  
When the function mode selection switch is located to "positive function" position, the green indication lamp will light, at this time, 4mA corresponds to full-close, 20mA corresponds to full-open; When the function mode selection switch is located to "negative function" position, the red indication lamp will light, at this time, 4mA corresponds to full-open, 20mA corresponds to full-close.
- 7) When the servo controller is first time energized, it is necessary to have calibration of actuator travel and valve angle, so as to establish the strict corresponding relationship, and then it can be put into normal use. The calibration can be completed by automatic calibration mode or by manual calibration mode (normally the customer is only requested to start the automatic calibration).

Automatic calibration: press "+" and "-" key at the same time for more than 2 seconds to start automatic calibration, at this time "manual / automatic" status indication lamp lights with yellow, and the actuator automatically completes the action of full-close and full-open and memorizes the valve, thus the automatic calibration is accomplished and the servo-controller is tuned to automatic status (green lamp lights).

Manual calibration: Turn the function mode selection switch to "manual calibration" position, the "manual / automatic" status indication lamp lights with yellow, the digital tube indicates "UL", press "+" and "-" key and make the actuator move to close direction, at this time the opening value of valve indicated in the window is getting smaller. When reaching to the respected zero position, press "A/M" key for confirmation, the digital tube turns to indicate "UH". Use the same method to have the manual calibration to the respected full position. At the time of ending the manual calibration, it is necessary to put the function mode selection switch back to the previous position.

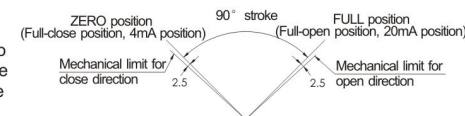

- 8) According to the needs of control, customer can check and reset the parameters according to following flow sheet.

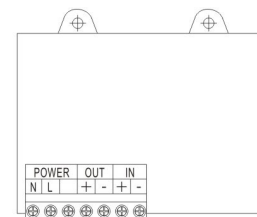
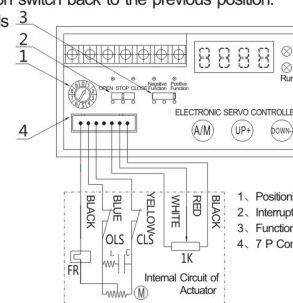

KZQ08-3A Type Servo-controller  
(suitable to EA - 20, 40, 60E)

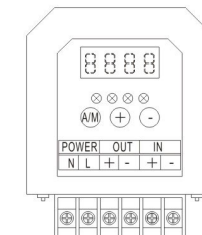
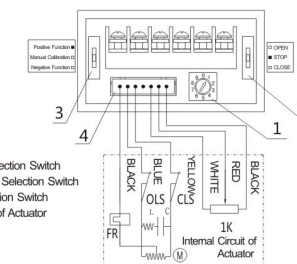

KZQ08-3B Type Servo-controller  
(suitable to EA - 05, 07, 10E)

- Turn slowly the adjusting knob for "open signal" (adjusting gear shaft) on the indication plate anti-clockwise by a small "—" screw driver, making the cam on D3 turn towards to roller at the micro-switch K3 and make the cam press on the roller. When the micro switch K3 being initiated, you can hear a sound of "click", and then stop the adjustment;
- When the valve moves to min. opening position (full-close position), the pointer is pointing at "●" 0% of scale line for opening. Turn slowly the adjusting knob for "close signal" (adjusting gear shaft) on the indication plate clockwise, making the cam on D4 turn towards to roller at the micro-switch K4 and make the cam press on the roller. When the micro switch K4 being initiated, you can hear a sound of "click", and then stop the adjustment;
- At ex-works, K3 and K4 are adjusted to full-open and full close of valve synchronously, and respectively output passive signals corresponding to full-open and full close of valve. In practice, customers can adjust it to the appropriate positions by themselves according to the needs of control.

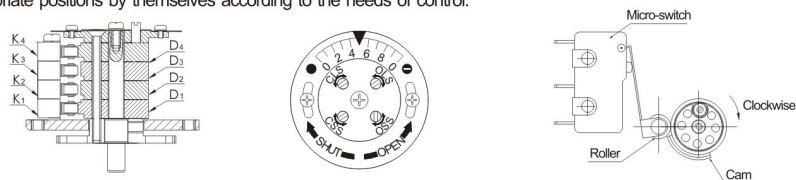

Fig. 8

6. Adjustment of Potentiometer (Fig 9, 10)

- Drive the actuator to the intermediate position by crank, and make the pointer point to 50% of the scale line.
- Measure the resistance at pin 1 and pin 3 of the potentiometer by means of universal meter, refer to Fig. 10. Write down the R value (If no special requirement, the factory had set it to  $1k\Omega \pm 15\%$ ).
- Apply appropriate force to the potentiometer mounting plate, and make the gear for opening be disengaged from the gear of potentiometer.
- Connect the universal meter, one end to the moving arm of the potentiometer (Pin 2) and another end to any pin of the potentiometer. Slowly turn the gear of potentiometer and observe the readings of the universal meter. When the resistance is  $R/2 \pm 2\Omega$ , stop the adjustment and cancel the force on the mounting plate, and make the gear for opening be engaged with the gear of potentiometer.

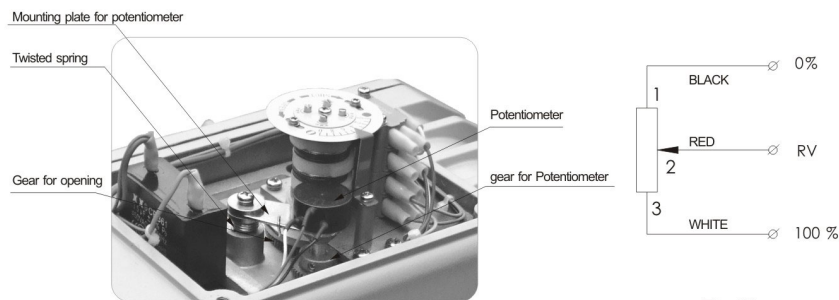

Fig. 9

Fig. 10

7. Electric Test-run

- Make correct wiring according to the control circuit drawing adhered inside the cover for junction box, turn on the power after confirmation;
- Put the switch to the close position, the actuator drives the valve to run towards to closing position (clockwise), and the electric actuator stops running till travel switch K1 (cls) is initiated.
- Put the switch to the open position, the actuator drives the valve to run towards to full-open position (anticlockwise), and the electric actuator stops running till travel switch K2 (ols) is initiated.
- With the correct adjustment mentioned above, if the positions of the indication pointer and the valve are found not in the positions they should be, (mostly due to position deviation of valve shaft and coupling during processing) please loose the screws at the two ends of scale plate shown in Fig. 5 and Fig. 8, turn the scale plate to the corrected indication positions and fix the screws. (Note: not to loose the pointer)

OVERALL DIMENSION DRAWINGS FOR EA-05

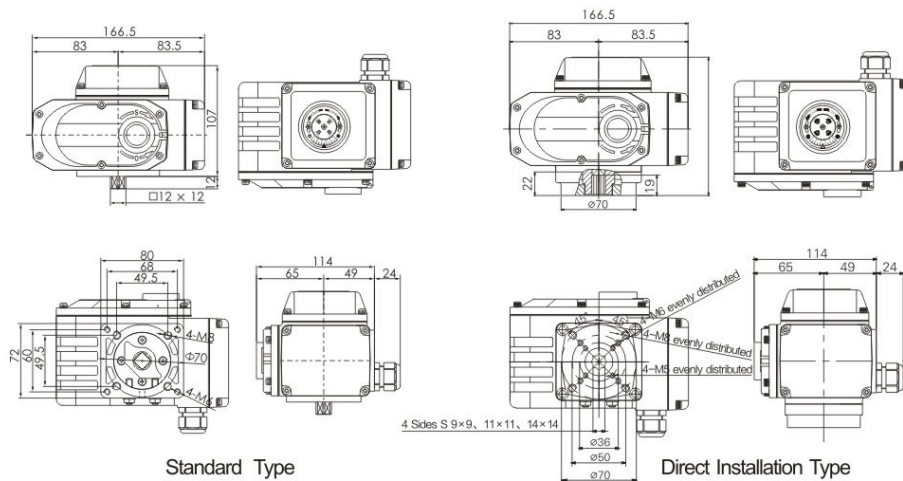

Type Parameters	EA-05				
	DC24	AC24	AC110	AC220	AC380
Performance					
90°Standard, Time/Torque	20S/50Nm				
90°Selectable, Time/Torque	4S/20Nm 10S/30Nm 60S/50Nm				
Turning Angle (°)	0~360				
Motor Power (W)	13	10	10	10	6
Rated Current (A)	1.28	1.52	0.22	0.16	0.08
Total Weight (Kg)	2.5				
Insulation Resistance (MΩ)	DC/AC24V:100 /250VDC AC110/220/380V:100 /500VDC				
Voltage-withstand Class	DC/AC24V:AC500V/ one minute AC110/220V:AC1500V/one minute AC380V:AC1800V/ one minute				
Protection Class of casing	IP 67				
Installation Angle	360° at any angle				
Electric Interface	One G1/2 Water-proof Cable Connector ( For type with 4~20mADC control signal, two connectors shall be provided.)				
Ambient Temperature (°C)	-30~+60				
Optional Control Circuit	Type A: Ordinal switch type; Type B: Passive signal feedback type; Type C : Resistance signal feedback type Type D: Resistance signal and passive signal feedback type; Type E: Adjusting type; Type F: With position transmitter; Type G: DC current control type; Type H: AC 380V power control type				
Optional Function	★Stainless steel support, coupling ★Direct installation board, coupling (ISO5211 Standard) ★Over torque protector ★Heater for eliminating moisture				

OVERALL DIMENSION DRAWINGS FOR  
EA-10

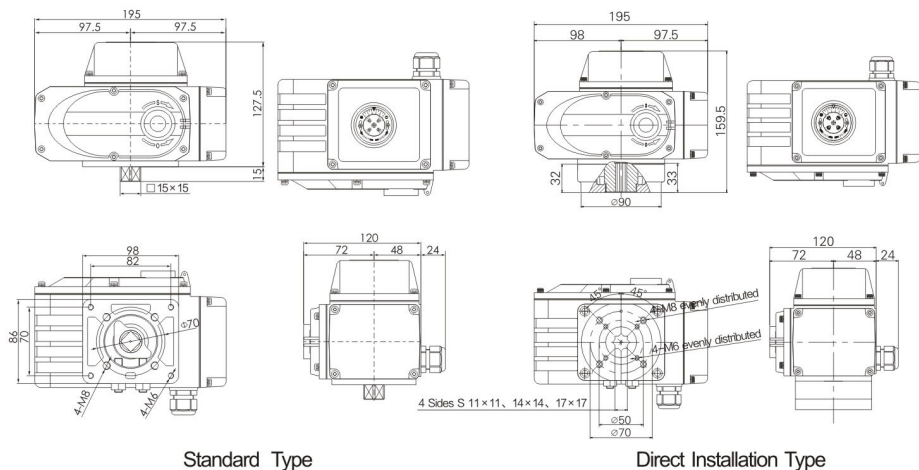

Standard Type

Direct Installation Type

Parameters	Type EA-10				
	DC24	AC24	AC110	AC220	AC380
Performance					
90°Standard, Time/Torque	30S/100Nm				
90°Selectable, Time/Torque	4S/30Nm 15S/50Nm 20S/70Nm 60S/100Nm				
Turning Angle (°)	0~360				
Motor Power (W)	25	25	25	25	15
Rated Current (A)	2.05	2.12	0.57	0.32	0.10
Total Weight (Kg)	3.5				
Insulation Resistance (MΩ)	DC/AC24V:100/250VDC AC110/220/380V:100/500VDC				
Voltage-withstand Class	DC/AC24V:AC500V/ one minute AC110/220V:AC1500V/one minute AC380V:AC1800V/ one minute				
Protection Class of casing	IP 67				
Installation Angle	360° at any angle				
Electric Interface	One G1/2 Water-proof Cable Connector ( For type with 4~20mADC control signal, two connectors shall be provided.)				
Ambient Temperature (°C)	-30~+60				
Optional Control Circuit	Type A: Ordinal switch type; Type B: Passive signal feedback type; Type C : Resistance signal feedback type Type D: Resistance signal and passive signal feedback type; Type E: Adjusting type; Type F: With position transmitter; Type G: DC current control type; Type H: AC 380V power control type				
Optional Function	★Stainless steel support, coupling ★Direct installation board, coupling (ISO5211 Standard) ★Over torque protector ★Heater for eliminating moisture				

3、Adjustment of Travel Switch (Electric Protection), refer to Fig. 5

- 1) Drive the valve to Full Close position by crank.
- 2) Turn slowly the adjusting knob (adjusting gear shaft) on the indication plate to full-close position clockwise by a small “—” screw driver, making the cam on D1 turn towards to the roller and press on the roller and. When the micro switch K1 being initiated, you can hear a sound of “click” , and then stop the adjustment.
- 3) Drive the valve to Full Open position. Turn slowly the adjusting knob (adjusting gear shaft) on the indication plate to full-open position anti-clockwise by a small “—” screw driver, making the cam on D2 turn towards to the roller and make the top of the cam press on the roller. When the micro switch K2 being initiated, you can hear a sound of “click” , and then stop the adjustment.

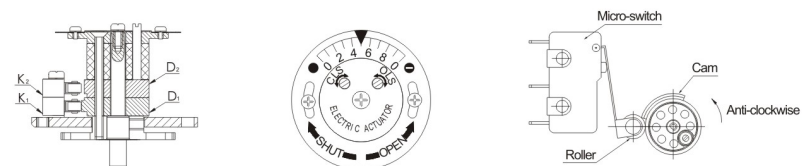

Fig. 5

4、Adjustment of Mechanical Limit (Mechanical Protection), refer to Fig. 6 , 7.

- 1) After correct adjustment of electric protection, it is necessary to conduct the adjustment of mechanical protection.
- 2) Drive the valve to full-close position (CLS) manually or electrically and make limit switch for full-close position to move, when the limit switch moves, you can here clear sound of “click” .
- 3) Loose the lock nut on the right side, turn the adjusting screw of limit switch for closing clockwise by wrench and make the adjusting screw be contact with the mechanical limit dog, and then turn back the adjusting screw anti-clockwise by half ring, make the moving of mechanical limit for full-close position delayed 2.5° angle distance of the electric limit, lock the lock nut.
- 4) Use the same way to adjust the mechanical limit for full-open position on the left side.
- 5) After the adjustment, the effective stroke of electric actuator, electric limit and mechanical limit shall meet the requirements of Fig. 7, which means under abnormal conditions the switch for stroke shall be protected electrically. Only after the stroke switch being defected, the mechanical switches shall be initiated. During operation, if mechanical switch is advance or coincidence with the electrical limit, the motor’ s turning will be blocked at full-open or full-close position, the motor will be overheated or burn out if not handle it in time.

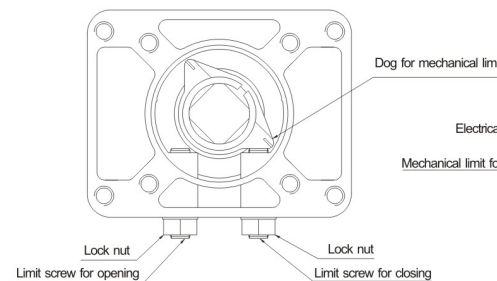

Fig. 6

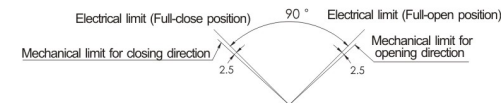

Fig. 7

5、Adjustment of intermediate position switch (Fig. 8)

- 1) Drive the valve to the max. opening position (full-open position) by crank or electrically, at this time, the pointer is pointing at “100%” of scale line for opening;

2. Installation of Electric Actuator onto Valve (Fig. 3 and Fig. 4)

- ① Operate the movement of valve manually or by means of tool and check if there is any abnormal conditions and make the valve to the full close position;
- ② Install the support to the valve;
- ③ Put one end of the coupling into the shaft of valve.
- ④ Drive the electric actuator to the full close position electrically or manually (pointer is pointing at “●” percentage of scale line for opening, which is at the starting position of scale), insert the output shaft into the square hole of coupling.
- ⑤ Fasten connecting bolts to connect support with electric actuator and the body of valve.
- ⑥ Drive the electric actuator by crank and confirm the operation is stable without off center and distortion, check the valve, see if the full close and full open positions can be realized within the indication range of opening indicator of electric actuator.

Note: Too much force when operating with the crank will lead the electric actuator over-travel and being damaged.

Special Hints:

Please be noted to those customers who provide the support and coupling by their own:

- The support and coupling shall be designed and processed by the professional mechanical technicians and meet the requirements noted in Fig. 3.
- The necessary accuracy of square holes at two ends of coupling shall be guaranteed, try as much as possible to eliminate driving clearance, so as to avoid backlash (Reciprocating Error) during operation of valve.
- It is necessary to guarantee the position degree of square holes at the two ends of coupling. Otherwise, it may exceed the working range designed for actuator, leading to that valve could not work normally due to the travel of actuator not able to be adjusted.

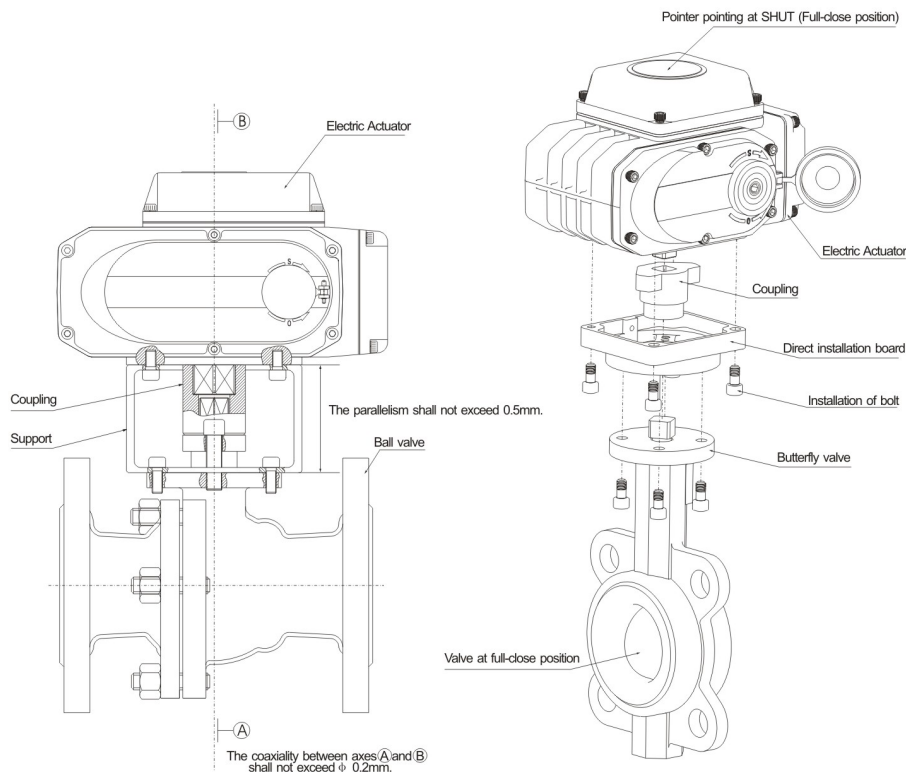
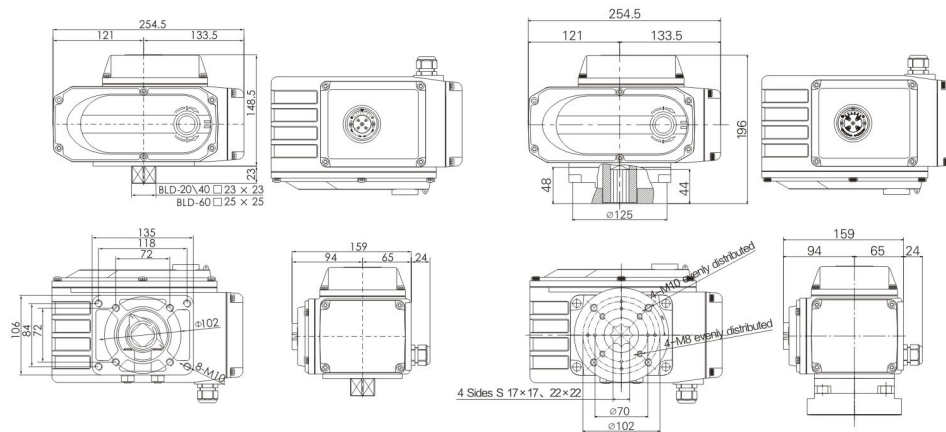

Fig. 3

Fig. 4

OVERALL DIMENSION DRAWINGS FOR EA-20/40/60



Standard Type

Direct Installation Type

Type Parameters	EA-20				EA-40				EA-60			
	DC24	AC110	AC220	AC380	DC24	AC110	AC220	AC380	DC24	AC110	AC220	AC380
Performance	30S/200Nm				30S/400Nm				45S/600Nm			
90°Standard, Time/Torque	30S/200Nm				30S/400Nm				45S/600Nm			
90°Selectable, Time/Torque	4S/50Nm	15S/100Nm	60S/200Nm		4S/100Nm	15S/200Nm	60S/400Nm					
Turning Angle (°)	0~90											
Motor Power (W)	35	40	40	30	70	90	90	40	70	90	90	40
Rated Current (A)	3.57	0.69	0.32	0.15	5.13	1.16	0.54	0.28	6.04	1.20	0.64	0.28
Total Weight (Kg)	8.0				8.5				9.0			
Insulation Resistance (MΩ)	DC/AC24V:100/250VDC				AC110/220/380V:100/500VDC							
Voltage-withstand Class	DC/AC24V:AC500V/ one minute				AC110/220V:AC1500V/one minute				AC380V:AC1800V/ one minute			
Protection Class of casing	IP 67											
Installation Angle	360° at any angle											
Electric Interface	One G1/2 Water-proof Cable Connector ( For type with 4~20mADC control signal, two connectors shall be provided.)											
Ambient Temperature (°C)	-30~+60											
Optional Control Circuit	Type A: Ordinal switch type; Type B: Passive signal feedback type; Type C: Resistance signal feedback type Type D: Resistance signal and passive signal feedback type; Type E: Adjusting type; Type F: With position transmitter; Type G: DC current control type; Type H: AC 380V power control type											
Optional Function	★Stainless steel support, coupling ★Direct installation board, coupling (ISO5211 Standard) ★Over torque protector ★Heater for eliminating moisture											

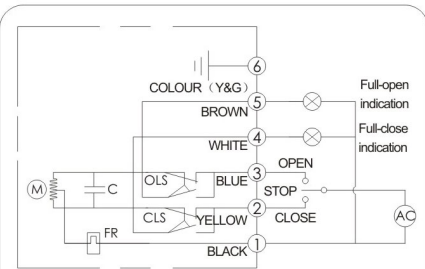

**Type s :** Limit Switch (Standard Type)  
 Function: The opening or closing operation is realized by AC switching volume, and outputs a group of full open or full close active position signals

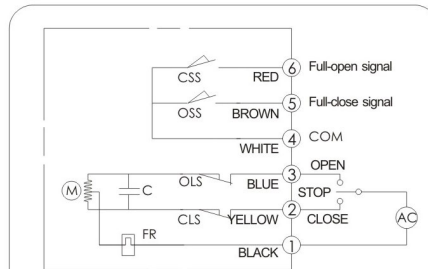

**Type ms :** With Intermediate Position Switch  
 Function: The opening or closing operation is realized by AC switching volume, and outputs a group of corresponding full open or full close position with passive contact.

Structure: With two intermediate position switches

Note: The full-close and full-open signal are generally adjusted to 1.5~2°, the advanced full close and full open limits at the time of ex-works.

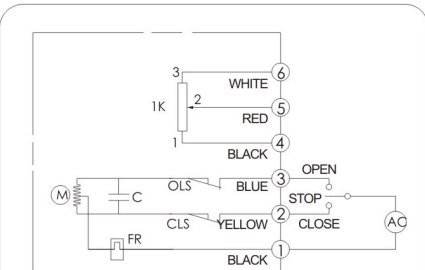

**Type P10:** With Potentiometer  
 Function: The opening operation is controlled by switching volume, and continuously outputs resistant signals corresponding to opening positions.  
 Structure: With 1 KΩ Potentiometer

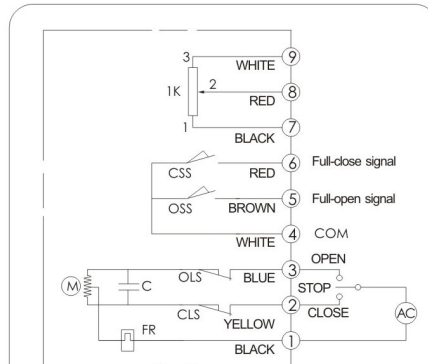

**Type SP :** With Potentiometer and intermediate position switch  
 Function: The opening operation is controlled by switching volume, and continuously outputs resistant signals corresponding to opening positions and at the same time a group of corresponding full-open and full-close passive contact signals.

Structure: With two intermediate position switches and a potentiometer.

Note: The full-close and full-open signal are generally adjusted to 1.5~2°, the advanced full close and full open limits at the time of ex-works.

1. Application Requirements

1) Requirement of Installation Conditions

- The casing of this product is with protection class of Ip68. It can be installed not only indoors, but also outdoors.
- The product is not explosion-proof one, care shall be taken to avoid inflammable and explosive environment.
- It is necessary to have protective cover installed to protect overall electric actuator if it operates in such conditions of long time raining, directly receiving

- Maintenance space for wiring and manual operation shall be reserved during the installation of equipment.
- The ambient temperature shall be within the rang of - 30 - +60°C.

2) Selection of support

- When electric actuator operates with valve, if the temperature of working medium inside the valve is high, due to the heat conductivity, the temperature of actuator shall be rising.
- The support of electric actuator connected with valve shall have the function of heat dispersion. It is possible to increase the height of support appropriately so as to

- enhance the heat dispersion effect.
- Please select the standard type support if the temperature of working medium is below 60°C.
- Please select longer support if the temperature of working medium is above 60°C.

3) Installation and Connection Requirements for Cable and Wire Pipe

- When the pipe for wire is used, please install according to the requirement of Fig. 1.
  - ① Outer diameter of wire pipe is Φ9~Φ11.
  - ② Waterproof shall be fully adopted.
  - ③ The electric actuator shall be allocated higher than the pipe, so water in the pipe will not flow into the actuator to damage the unit.
- The outer diameter of the cable shall be Φ9 - Φ11, refer to Fig. 2. No cable, which is not fit to the inner diameter of cable connector, is allowed to use, in particular, the multi-single wire can not be used to replace the cable. Otherwise, water may enter into the actuator to corrupt the parts inside actuator and damage the insulation, and cause the actuator seriously damaged.

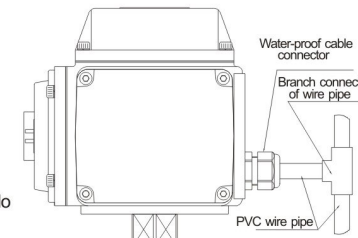

Fig. 1

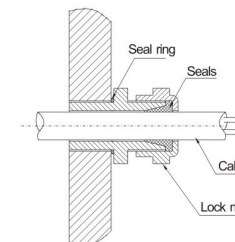

Fig. 2

4) Power Supply

- The power supply corresponding to that indicated in the name plate of actuator ordered must be provided at the installation site.
- Following requirements of power supply voltage shall be met at the installation site:
 

AC220V ± 10%	50/60HZ
AC110V ± 10%	50/60HZ
AC380V ± 10%	50/60HZ
DC24V ± 5%	

5) Selection of Fuses for Circuit Breaker

In order to protect electric actuator, eliminate hidden danger of short-circuit and reduce accidents, please additionally connect a circuit breaker at the input end of power supply of each electric actuator and select suitable fuse according to the following table:

Specification of Fuse Voltage Types of Products	AC220V	AC110V	AC380V	DC24V
BLD-02/05	2A	3A	1A	5A
BLD-10	3A	5A	2A	7A
BLD-20/40/60	5A	7A	3A	15A

Open Installation Type Electric Actuator

OVERALL DIMENSION DRAWINGS FOR EA-02

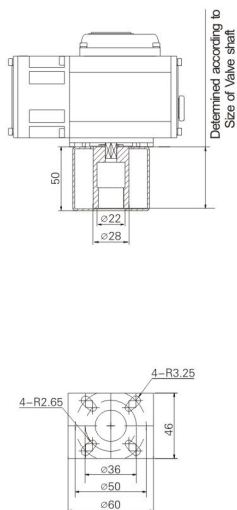

OVERALL DIMENSION DRAWINGS FOR EA-05

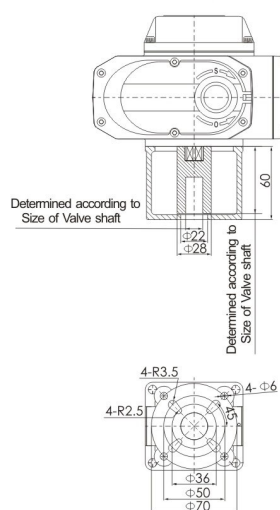

OVERALL DIMENSION DRAWINGS FOR EA-10

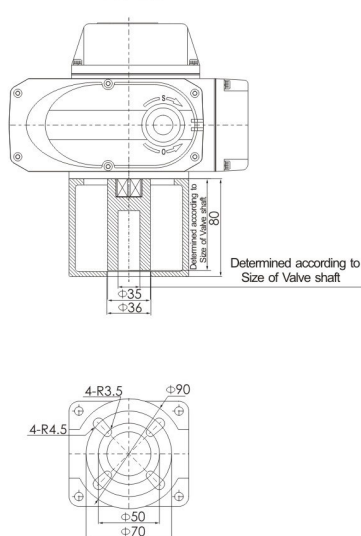

OVERALL DIMENSION DRAWINGS FOR EA-20/40/60

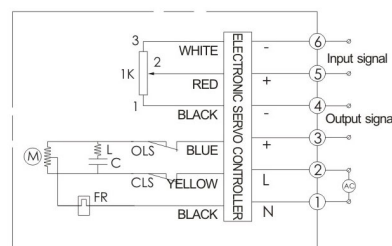
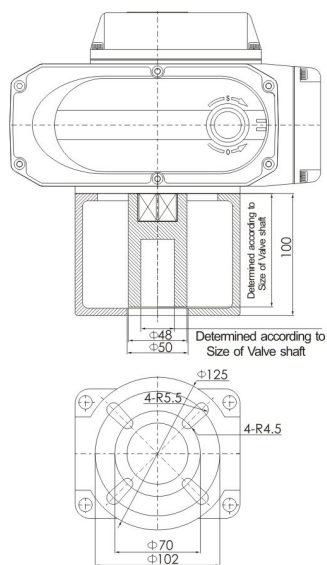

Type POU: With Servo Controller (Adjusting Type)  
 Function: The opening adjustment is realized by inputting an analog signal of 4~20mADC/1~5VDC externally, and continuously outputs a position signal of 4~20mADC.  
 Structure: With 1 KΩ Potentiometer and servo controller

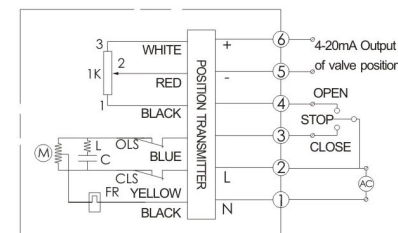

Type CPT: With Position Transmitter  
 Function: The opening operation is controlled by external AC switching volume, and continuously outputs a position signal of 4~20mADC.  
 Structure: With a potentiometer and a position transmitter

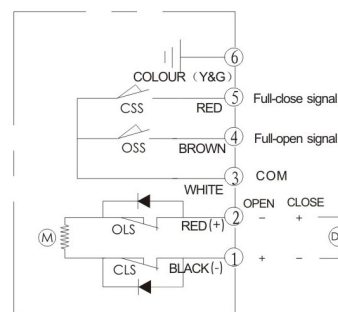

Type G : DC Control Type  
 Function: The opening or closing operation can be controlled by DC switching volume output from the exchange of the positive polarity and the negative polarity of external DC power supply and output a group of corresponding full open or full-close passive contact signals  
 Structure: With two intermediate position switches

Note: The full-close and full-open signal are generally adjusted to 1.5~2° , the advanced full close and full open limits at the time of ex-works.

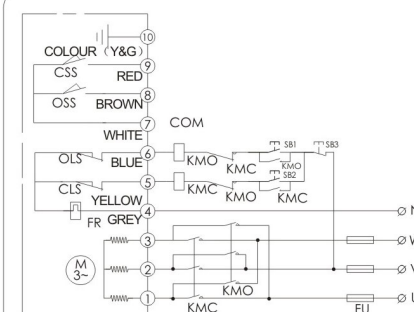

Type H: AC380V Control Type  
 Function: The opening or closing operation can be controlled by 3-phase AC switching volume output from external phase-reversing circuit, and outputs a group of corresponding full-open or full-close passive contact signal.  
 Structure: With two intermediate position switches

Note: The full-close and full-open signal are generally adjusted to 1.5~2° , the advanced full close and full open limits at the time of ex-works.

Performance Index of Adjusting Type (Type E)

Type Parameter Power Performance	BLD-05E	BLD-07E	BLD-10E	BLD-20E	BLD-40E	BLD-60E
	AC110/220	AC110/220	AC110/220	AC110/220	AC110/220	AC110/220
Output Torque (Nm)	50	70	100	200	400	600
Turning Angle (°)	0 ~ 90	0 ~ 90	0 ~ 90	0 ~ 90	0 ~ 90	0 ~ 90
Stroke time	20	20	30	30	30	45
Motor Power (W)	10	25	25	40	90	100
Rated Current (A)	0.25/0.16	0.56/0.30	0.56/0.32	0.69/0.32	1.16/0.54	1.20/0.64
Total Weight (Kg)	2.5	3.5	3.5	8	8.5	9
Input signal	4 ~ 20mADC 1 ~ 5VDC					
Output signal	4 ~ 20mADC					
Basic tolerance	not more than ± 0.5%					
Reciprocating Error	less than 0.5%					
Dead Space	0.4 ~ 1.5% adjustable (0.08 ~ 0.2mA)					
Damping Characteristic	0 times					
Repeating Error in Actuator	0%					
Insulation Resistance(MΩ)	100MΩ/500VDC					
Voltage-withstand Class	1500VAC/one minute					
Protection Class	IP68					
Installation Angle	360° at any angle					
Electric Interface	Two G1/2water-proof cable connectors ( including power cord and signal cable per each)					
Ambient Temperature(°C)	-30 ~ +60					
Optional Function	★ Stainless steel support, coupling ★ Direct installation board, coupling(ISO5211standard) ★ Over torque protector ★ Heater for eliminating moisture ★ Passive contact signal					

Dimension Drawings for Direct Installation Type Electric Actuator  
( ISO5211 Standard )

